



Standard Features	Options
<ul style="list-style-type: none"> / High efficiency AC driving motor / Special for truck's lifting motor / Multi-functions dashboard / Full electronic controlled travelling, lifting and steering / Front lighting system, turning indicator, LED combined three colors's rear lights / Big dimension rubber pad / Sheet metal stamping made front and rear bottom plate / Sheet metal stamping made left and right cover and battery cover / Reversing beeper / Full hydraulic steering / Storage box / Soft landing system / Standard forks in red / 3m duplex wide view mast / Tow coupling / Center located rear view mirror / Suspension seat with higher OHG / Turning speed is automatically reduced when steering for Model 2.0~3.5t / The cover below control panel are fully closed / Dashboard is relocated to overhead, no restriction of the operator's visibility / EPB: Electronic Parking Brake 	<ul style="list-style-type: none"> / Side way battery change / Big capacity Chinese made battery / Cold store application / High performance import battery / Battery charger / Rear lighting system / Front dual tyre / SE tyre / Non-marking tyre / Left and right rear view mirror / Reversing hand grip with horn button / Wide fork carriage / Wide or higher load backrest / Other dimension forks / Duplex mast with full free lift / Triplex mast / Integrated side shift / Other attachments / OPS / Blue spot light / Other specification on demand



Hangcha Europe GmbH

Mariechen-Graulich-Straße 12a,
65439 Flörsheim am Main,
Germany

Tel: 0049-61453769188
E-mail: admin@hangchaeurope.com

Mob: 0049-16096548808 (Thomas Dittrich)
E-mail: thomas.dittrich@hangchaeurope.com
Zip Code Area (1,2,3,4,5,6,7)

Mob: 0049-1605272481 (Jens Abmuth)
E-mail: jens.assmuth@hangchaeurope.com
Zip Code Area (0,8,9)

www.hangchaeurope.com



Follow us on
Instagram



Follow us on
Facebook



Follow us on
YouTube



Download "Hangcha
Forklift" App



ISO14001:2015



ISO9001:2015



HANGCHA trucks conform
to the European Safety
Requirements.

HANGCHA GROUP CO., LTD. reserves the right to make any changes without notice concerning colors, equipment, or specifications detailed in this brochure, or to discontinue individual models. The colors of trucks, delivered may differ slightly from those in brochures.

2021 VERSION 1/COPYRIGHT 2021/04

A Series Electric Forklift Truck

with capacities of 1,000 to 3,500kg

The World of Hangcha



LET THE LIUM POWER FREED



HANGCHA provides Li-Ion battery (LiFePO4) with 5 years or 10000 hours warranty.



5 YEARS WARRANTY

INNOVATIVE SOLUTIONS NEW POWER NOW

Innovative, reliable lithium-ion technology (Lithium Iron-Phosphate), which are developed jointly by HANGCHA and CATL. Battery cells and modules are from CATL, with reliable quality, exclusively for HANGCHA.

- / We use square lithium iron phosphate batteries and modules used in large quantities by commercial vehicles in mature economies.
- / The module uses an aluminum alloy frame which is sturdy, lightweight and with excellent heat dissipation.
- / Safe and effective: Charging efficiency as high as 98%, thermal runaway temperature 600 °C or above.
- / Adapted to low temperatures: Comes standard with an electrical heating feature, ensuring normal operation in low temperatures.
- / Quick charging: Can charge and operate at the same time, fully charged in 2 hours.
- / Long-working: 4000 charging cycles, capacity retention greater than 80%.
- / Maintenance-free: Battery does not require manual maintenance.
- / Green and clean: Pollution-free, zero emissions.

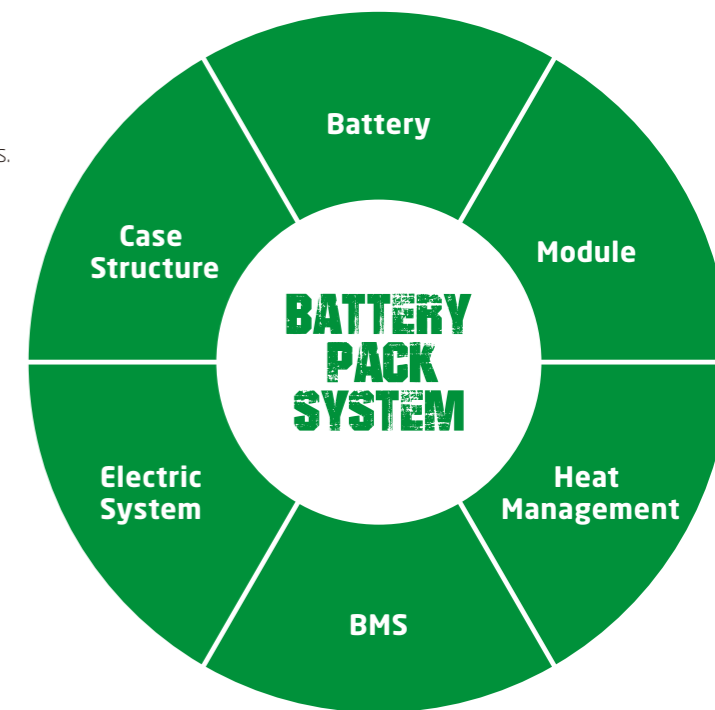

Li-Ion
2 hours
100%

Lead-acid batteries
8-10 hours 100%

Rapid charging and opportunity charging ensure continuous availability of vehicles

Li-Ion powered forklifts are always available. They allow for fast full charging or boost charging (100 % charge in 2 hours). They are maintenance free and do not require a battery change when used for multi-shift operations.



TITANS CHARGER

Li-Ion Battery Pack specification

Type		CPD10-AC4-EI	CPD15-AC4-EI	CPD18-AC4-EI	CPD20-AC4-EI	CPD25-AC4-EI	CPD25-ALC4-EI	CPD30-AC4-EI	CPD35-AC4-EI
Battery voltage, capacity	V/Ah	80/202	80/202	80/202	80/271	80/271	80/404	80/404	80/404
Titans charger		SLC-80100	SLC-80100	SLC-80100	SLC-80100	SLC-80100	SLC-80200	SLC-80200	SLC-80200

Appearance

Applied advanced new designing method, world famous designing company designed, make the eye catchable stream outline of the truck chassis. Small dimension, simple appearance, and metal material applied for the exposed parts, all provide robust construction of the A series.

Power Train



Stability

Advanced parallel layout of drive motor and lower located battery up to chassis bottom provide good stability to the truck.

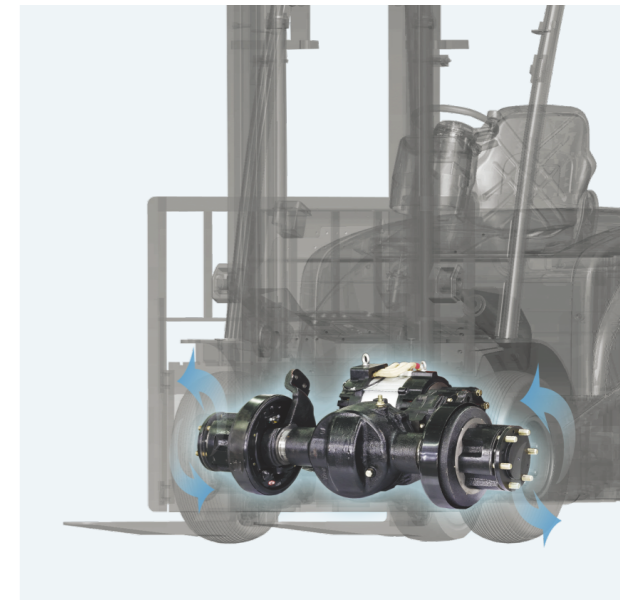

Intelligent

- / First-class R&D and testing facility.
- / First-class production quality management system.
- / First-class manufacturing facility.
- / First-class environment and control.



Comfortable Operation

Ergonomic

Easy to see dashboard is relocated to overhead, no restriction of the operator's visibility. The operator can monitor the truck operation at a glance.



Seat

The extra foot space is provided to reduce operator fatigue significantly. The new wide-open, non-slip step makes getting in and out easy and safe.



Soft landing

In addition to the soft landing system, the soft lifting system is adopted (front lifting cylinders of triplex mast and full free dup-lex mast), as a result, the noise and shock of the mast significantly decreases.



EPB

Electronic Parking Brake, it provides the safe and rapid brake performance. More particularly, turn on the function automatically under different working situation.



Advanced

High frequency MOSFET controller provides accurate control of travelling, lifting, and better adjustable performance, and better matches the motor. Regenerative braking, reverse current braking and anti-slide on slope function guarantee the operation safety.

Multi functions big LED dashboard provides running hours, battery power, and self diagnosis functions, and with high accuracy even in bad environment.

Regenerative braking is more energy saving and efficiency during truck's deceleration, direction changing, and driving on downwards slope.

C3/C4 system



CURTIS big LED dashboard. Non-handset Operation



Imported high performance, and new generation AC controller

Z3/Z4 system



HANGCHA dashboard

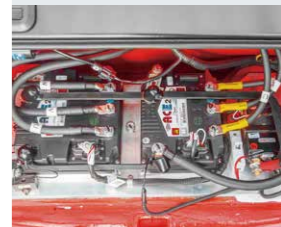

ZAPI controller

1. Low center of gravity provides good turning stability, and better operator's driving comfort. 150mm adjustable distance of seat provides better operator's comfort of different operators.
2. Soft landing system is applied for A series. When the forks lower to 60-100mm to ground, the soft landing system is auto operated, and to avoid the forks dashing against the ground. New designed broad view mast provides better forward visibility.
3. Easy to see LED dashboard provides friendly interaction.
4. Low noise, no exhaust emission, and low energy consumption, all meet environment friendly requirement.



Service Ability

Full open battery cover, easy for battery service easy opened counter weight cover, to protect internal controller to avoid water and dust World famous brand electronics are applied in motor controller, contactor, power plug, emergency switch, dashboard, and accelerators.

Overloaded protection system is applied for electronics and hydraulics.

CE certificate is available.

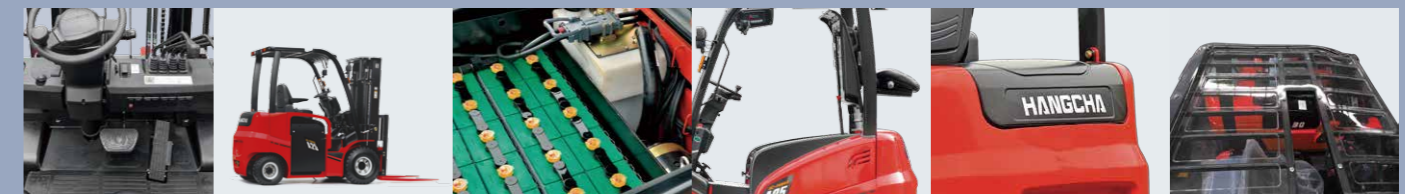

The cover below control panel are fully closed

Side battery changing solution is applied for heavy and long time application

Battery cover with auto lock spring for easy battery service and replacing, and clean the oil tank

Full opened engine hood

Easy opened counterweight cover is to protect the internal controllers to avoid water and dust

Protective roof

A Series 1.0-3.5t Electric Forklift Specification

Distinguishing mark	1.1	Manufacturer	HANGCHA GROUP CO.,LTD.																								
	1.2	Manufacturers type designation	CPD10-AC3-E	CPD15-AC3-E	CPD18-AC3-E	CPD20-AC3-E	CPD25-AC3-E	CPD25-ALC3-E	CPD30-AC3-E	CPD35-AC3-E	CPD10-AC4-E	CPD15-AC4-E	CPD18-AC4-E	CPD20-AC4-E	CPD25-AC4-E	CPD25-ALC4-E	CPD30-AC4-E	CPD35-AC4-E	CPD10-AZ3-E	CPD15-AZ3-E	CPD18-AZ3-E	CPD20-AZ3-E	CPD25-AZ3-E	CPD25-ALZ3-E	CPD30-AZ3-E	CPD35-AZ3-E	
1.3	Drive: electric (battery or mains), diesel, petrol, fuel gas	electric	electric	electric	electric	electric	electric	electric	electric	electric	electric	electric	electric	electric	electric	electric	electric	electric	electric	electric	electric	electric	electric	electric	electric	electric	electric
1.4	Operator type: hand, pedestrian, standing, seated, order-picker	seated	seated	seated	seated	seated	seated	seated	seated	seated	seated	seated	seated	seated	seated	seated	seated	seated	seated	seated	seated	seated	seated	seated	seated	seated	seated
1.5	Load capacity/rated load	Q (kg)	1000	1500	1800	2000	2500	2500	3000	3500	1000	1500	1800	2000	2500	2500	3000	3500	1000	1500	1800	2000	2500	2500	3000	3500	
1.6	Load centre distance	c (mm)	500	500	500	500	500	500	500	500	500	500	500	500	500	500	500	500	500	500	500	500	500	500	500	500	
1.8	Load distance, centre of drive axle to fork	x (mm)	406	406	411	448	448	448	480	485	406	406	411	448	448	448	480	485	406	406	411	448	448	448	480	485	
1.9	Wheelbase	y (mm)	1380	1380	1380	1485	1485	1625	1625	1625	1380	1380	1380	1485	1485	1625	1625	1625	1380	1380	1380	1485	1485	1625	1625	1625	
Weight	2.1	Service Weight	kg	2940	2940	3090	3880	4180	4380	4850	2940	2940	3090	3880	4180	4380	4850	5300	2940	2940	3090	3880	4180	4380	4850	5300	
	2.2	Axle loading, laden front/rear	kg	3120/820	3900/540	4300/590	5196/684	5920/760	6140/740	7060/790	7950/850	3120/820	3900/540	4300/590	5196/684	5920/760	6140/740	7060/790	7950/850	3120/820	3900/540	4300/590	5196/684	5920/760	6140/740	7060/790	7950/850
	2.3	Axle loading, unladen front/rear	kg	1353/1587	1353/1587	1440/1650	1728/2152	1780/2400	1930/2450	2324/2526	2380/2920	1353/1587	1353/1587	1440/1650	1728/2152	1780/2400	1930/2450	2324/2526	2380/2920	1353/1587	1353/1587	1440/1650	1728/2152	1780/2400	1930/2450	2324/2526	2380/2920
Tyres, chassis	3.1	Tyres: solid rubber, superelastic, pneumatic, polyurethane	pneumatic	pneumatic	pneumatic	pneumatic	pneumatic	pneumatic	pneumatic	super elastic	pneumatic	pneumatic	pneumatic	pneumatic	pneumatic	pneumatic	pneumatic	super elastic	pneumatic	pneumatic	pneumatic	pneumatic	pneumatic	pneumatic	pneumatic	pneumatic	super elastic
	3.2	Tyre size, front	6.00 - 9	6.00 - 9	21x8 - 9	23x9 - 10	23x9 - 10	23x9 - 10	23x9 - 10	23x9 - 10	23x10 - 12	6.00 - 9	6.00 - 9	21x8 - 9	23x9 - 10	23x9 - 10	23x9 - 10	23x9 - 10	23x9 - 10	6.00 - 9	6.00 - 9	21x8 - 9	23x9 - 10	23x9 - 10	23x9 - 10	23x9 - 10	23x10 - 12
	3.3	Tyre size, rear	5.00 - 8	5.00 - 8	5.00 - 8	18x7 - 8	18x7 - 8	18x7 - 8	18x7 - 8	18x7 - 8	200/50-10	5.00 - 8	5.00 - 8	5.00 - 8	18x7 - 8	18x7 - 8	18x7 - 8	18x7 - 8	18x7 - 8	5.00 - 8	5.00 - 8	5.00 - 8	18x7 - 8	18x7 - 8	18x7 - 8	18x7 - 8	200/50-10
	3.5	Wheels, number front rear (x = driven wheels)	2x/2	2x/2	2x/2	2x/2	2x/2	2x/2	2x/2	2x/2	2x/2	2x/2	2x/2	2x/2	2x/2	2x/2	2x/2	2x/2	2x/2	2x/2	2x/2	2x/2	2x/2	2x/2	2x/2	2x/2	2x/2
	3.6	Tread, front	b10 (mm)	888	888	938	1058	1058	1058	1058	1068	888	888	938	1058	1058	1058	1058	1068	888	888	938	1058	1058	1058	1058	1068
	3.7	Tread, rear	b11 (mm)	897.5	897.5	897.5	960	960	960	960	960	897.5	897.5	897.5	960	960	960	960	960	897.5	897.5	897.5	960	960	960	960	960
	3.8	Tilt of mast/fork carriage forward/backward	Grad	5/10	5/10	5/10	5/10	5/10	5/10	5/10	5/10	5/10	5/10	5/10	5/10	5/10	5/10	5/10	5/10	5/10	5/10	5/10	5/10	5/10	5/10	5/10	5/10
Dimensions	4.2	Height, mast lowered	h1 (mm)	1976	1976	1976	2006	2006	2006	2036	1976	1976	1976	2006	2006	2006	2036	2186	1976	1976	1976	2006	2006	2006	2036	2186	
	4.3	Free lift	h2 (mm)	145	145	145	140	140	140	145	145	145	145	140	140	140	145	150	145	145	145	140	140	140	145	150	
	4.4	Lift	h3 (mm)	3000	3000	3000	3000	3000	3000	3000	3000	3000	3000	3000	3000	3000	3000	3000	3000	3000	3000	3000	3000	3000	3000	3000	
	4.5	Height, mast extended	h4 (mm)	3955	3955	3955	4056	4056	4056	4152	4152	3955	3955	3955	4056	4056	4056	4056	4152	4152	3955	3955	3955	4056	4056	4056	
	4.7	Height of higher overhead guard(cabin) .	h6 (mm)	2130	2130	2130	2155	2155	2190	2190	2190	2130	2130	2130	2155	2155	2190	2190	2190	2130	2130	2130	2155	2155	2190	2190	
	4.8	Seat height relating to SIP/stand height	h7 (mm)	1045	1045	1045	1070	1070	1070	1070	1070	1045	1045	1045	1070	1070	1070	1070	1070	1045	1045	1045	1070	1070	1070	1070	
	4.12	Coupling height	h10 (mm)	275	275	275	303	303	303	303	303	275	275	275	303	303	303	303	303	275	275	275	303	303	303	303	
	4.19	Overall length	l1 (mm)	3018	3018	3023	3402	3402	3543	3575	3660	3018	3018	3023	3402	3402	3543	3575	3660	3018	3018	3023	3402	3402	3543	3575	
	4.20	Length to face of forks	l2 (mm)	2098	2098	2103	2332	2332	2473	2505	2590	2098	2098	2103	2332	2332	2473	2505	2590	2098	2098	2103	2332	2332	2473	2505	
	4.21	Overall width	b1 (mm)	1120	1120	1138	1265	1265	1265	1265	1302	1120	1120	1138	1265	1265	1265	1302	1302	1120	1120	1138	1265	1265	1265	1302	
	4.22	Fork dimensions ISO 2331	s/e/l (mm)	35/100/920	35/100/920	35/100/920	40/122/1070	40/122/1070	40/122/1070	45/125/1070	50/125/1070	35/100/920	35/100/920	35/100/920	40/122/1070	40/122/1070	40/122/1070	45/125/1070	50/125/1070	35/100/920	35/100/920	35/100/920	40/122/1070	40/122/1070	40/122/1070	45/125/1070	50/125/1070
	4.23	Fork carriage ISO 2328, class/type A,B		ISO2328 2A	ISO2328 2A	ISO2328 2A	ISO2328 2A	ISO2328 2A	ISO2328 2A	ISO2328 3A	ISO2328 3A	ISO2328 2A	ISO2328 2A	ISO2328 2A	ISO2328 2A	ISO2328 2A	ISO2328 2A	ISO2328 3A	ISO2328 3A	ISO2328 2A	ISO2328 2A	ISO2328 2A	ISO2328 2A	ISO2328 2A	ISO2328 2A	ISO2328 3A	ISO2328 3A
	4.24	Fork-carriage width	b3 (mm)	1000	1000	1000	1038	1038	1038	1100	1100	1000	1000	1000	1038	1038	1038	1100	1100	1000	1000	1000	1038	1038	1038	1100	1100
	4.25	Distance between fork-arms	b5(mm)	240/1000	240/1000	240/1000	260/1038	260/1038	260/1038	290/1100	290/1100	240/1000	240/1000	240/1000	260/1038	260/1038	260/1038	290/1100	290/1100	240/1000	240/1000	240/1000	260/1038	260/1038	260/1038	290/1100	290/1100
	4.31	Ground clearance, laden, below mast	m1 (mm)	85	85	85	85	95	95	95	95	85	85	85	85	95	95	95	95	85	85	85	85	95	95	95	
	4.32	Ground clearance, centre of wheelbase	m2 (mm)	110	110	110	120	120	120	120	125	110	110	110	120	120	120	120	125	110	110	110	120	120	120	125	
	4.33	Aisle width for pallets 1000 x 1200 crossways	Ast (mm)	3506	3506	3511	3738	3738	3878	3910	3995	3506	3506	3511	3738	3738	3878	3910	3995	3506	3506	3511	3738	3738	3878	3910	
	4.34	Aisle width for pallets 800 x 1200 crossways	Ast (mm)	3706	3706	3711	3938	3938	4078	4110	4195	3706	3706	3711	3938	3938	4078	4110	4195	3706	3706	3711	3938	3938	4078	4110	
	4.35	Turning radius	Wa (mm)	1900	1900	1900	2090	2090	2230	2230	2310	1900	1900	1900	2090	2090	2230	2230	2310	1900	1900	1900	2090	2090	2230	2230	
	4.36	Internal turning radius	b13 (mm)	620	620	680	730	730	730	730	730	620	620	680	730	730	730	730	730	620	620	680	730	730	730	730	
Performance data	5.1	Travel speed, laden/unladen	km/h	14/14	14/14	13.5/14	14/14	14/14	14/14	12/13	14/14	14/14	13.5/14	14/14	14/14	14/14	14/14	12/13	14/14	14/14	14/14	13.5/14	14/14	14/14	14/14	12/13	
	5.2	Lift speed, laden/unladen	mm/s	290/440	290/440	285/440	280/440	230/430	230/430	250/400	210/400	290/440	290/440	285/440	280/440	230/430	230/430	250/400	210/400	290/440	290/440	285/440	280/440	230/430	230/430	250/400	
	5.3	Lowering speed, laden/unladen	mm/s	300/410	300/410	275/420	285/420	215/410	215/410	260/390	260/370	300/410	300/410	275/420	285/420	215/410	215/410	260/390	260/370	300/410	300/410	275/420	285/420	215/410	215/410	260/390	
	5.5	Drawbar pull, laden/unladen	N	9000/10000	9000/10000	9500/11000	12000/12500	16000/17000	16000/17000	20000/21000	20500/21000	9000/10000	9000/10000	9500/11000	12000/12500	16000/17000	16000/17000	20000/21000	20500/21000	9000/10000	9000/10000	9500/11000	12000/12500	16000/17000	16000/17000	20000/21000	
	5.6	Max. Drawbar pull, laden/unladen	N	11000	11000	12000	14000	18000	18000	22000	23000	11000	11000	12000	14000	18000	18000	22000	23000	11000							

A Series 1.0-3.5t Electric Forklift Specification

Distinguishing mark	HANGCHA GROUP CO.,LTD.									
	CPD10-A24-E	CPD15-A24-E	CPD18-A24-E	CPD20-A24-E	CPD25-A24-E	CPD25-AL24-E	CPD30-A24-E	CPD35-A24-E		
1.1	Manufacturer									
1.2	Manufacturers type designation									
1.3	Drive: electric (battery or mains), diesel, petrol, fuel gas									
1.4	Operator type: hand, pedestrian, standing, seated, order-picker									
1.5	Load capacity/rated load									
1.6	Load centre/distance									
1.8	Load distance, centre of drive axle to fork									
1.9	Wheelbase									
2.1	Service Weight									
2.2	Axle loading, laden front/rear									
2.3	Axle loading, unladen front/rear									
3.1	Tyres: solid rubber, superelastic, pneumatic, polyurethane									
3.2	Tyre size, front									
3.3	Tyre size, rear									
3.5	Wheels, number front rear (x = driven wheels)									
3.6	Tread, front									
3.7	Tread, rear									
4.1	Tilt of mast/fork carriage forward/backward									
4.2	Height, mast lowered									
4.3	Free lift									
4.4	Lift									
4.5	Height, mast extended									
4.7	Height of higher overhead guard(cabin)									
4.8	Seat height relating to SIP/stand height									
4.12	Coupling height									
4.19	Overall length									
4.20	Length to face of forks									
4.21	Overall width									
4.22	Fork dimensions ISO 2331									
4.23	Fork carriage ISO 2328, class/type A,B									
4.24	Fork-carriage width									
4.25	Distance between fork-arms									
4.31	Ground clearance, laden, below mast									
4.32	Ground clearance, centre of wheelbase									
4.33	Aisle width for pallets 1000 x 1200 crossways									
4.34	Aisle width for pallets 800 x 1200 crossways									
4.35	Turning radius									
4.36	Internal turning radius									
5.1	Travel speed, laden/unladen									
5.2	Lift speed, laden/unladen									
5.3	Lowering speed, laden/unladen									
5.5	Drawbar pull, laden/unladen									
5.6	Max. Drawbar pull, laden/unladen									
5.7	Gradeability, laden/unladen									
5.8	Max. gradeability, laden/unladen									
5.9	Acceleration time, laden/unladen (0-10m)									
5.10	Service brake									
5.11	Parking brake									
6.1	Drive motor rating S2 60 min									
6.2	Lift motor rating at S3 15%									
6.3	Battery acc. to DIN 43 531/35/36 A,B,C, no									
6.4	Battery voltage, nominal capacity K5									
6.5	Battery weight									
6.6	Battery dimensions									
6.7	Energy consumption acc. to VDI cycle									
6.8	Min. battery weight									
6.9	Max. battery weight									
8.1	Manufacturer of controller									
8.2	Operating pressure for attachments									
8.3	Oil volume for attachments									
8.4	Sound level at the driver's ear according to EN / DIN 12 053									
8.5	Towing coupling, type DIN 15170									

A series 1.0t/1.5t/1.8t/2.0t mast specification

Type	Model	Lifting height	Lowered height	Extended height		Free lifting height				Tilting range		Capacity (Mast vertical to ground)					
				With backrest	Without backrest	With backrest	Without backrest	Forward	Backward	Load center@500mm Single Tire		Load center@500mm Front Dual Tire					
		mm	mm	mm	mm	mm	mm	mm	mm	(°)	(°)	1.0t	1.5t	1.8t	1.0t	1.5t	1.8t
2-stage wide view mast	M250	2500	1726	3455	3063	145	150	145	150	5	6	1000	1500	1800	1000	1500	1800
	M270	2700	1826	3655	3263	145	150	145	150	5	6	1000	1500	1800	1000	1500	1800
	M300	3000	1976	3955	3563	145	150	145	150	5	10	1000	1500	1800	1000	1500	1800
	M330	3300	2126	4255	3863	145	150	145	150	5	10	1000	1500	1800	1000	1500	1800
	M350	3500	2226	4455	4063	145	150	145	150	5	10	1000	1500	1800	1000	1500	1800
2-stage full-free lifting mast	M250	2500	1726	3455	3095	781	781	1141	1141	5	6	1000	1500	1800	1000	1500	1800
	U270	2700	1826	3655	3295	881	881	1241	1241	5	6	1000	1500	1800	1000	1500	1800
	U300	3000	1976	3955	3595	1031	1031	1391	1391	5	10	1000	1500	1800	1000	1500	1800
	U330	3300	2126	4255	3895	1181	1181	1541	1541	5	10	1000	1500	1800	1000	1500	1800
	U360	3600	2276	4555	4195	1331	1331	1691	1691	5	10	1000	1500	1800	1000	1500	1800
3-stage full-free lifting mast	U400	4000	2526	4955	4595	1581	1581	1941	1941	5	10	1000	1500	1800	1000	1500	1800
	N400	4000	1976	4955	4736	1031	1031	1250	1250	5	6	1000	1500	1750	1000	1500	1800
	N430	4300	2076	5255	5036	1131	1131	1350	1350	5	6	1000	1500	1650	1000	1500	1750
	N450	4500	2086	5465	5105	1141	1141	1501	1501	5	6	1000	1500	1650	1000	1500	1750
	N480	4800	2201	5755	5411	1256	1256	1600	1600	5	6	1000	1400	1600	1000	1500	1700
3-stage full-free lifting mast	N500	5000	2251	5955	5595	1306	1306	1666	1666	5	6	1000	1400	1550	1000	1500	1600
	N550	5500	2426	6455	6095	1481	1481	1841	1841	3	6	1000	1250	1500	1000	1350	1600
	N600	6000	2651	6955	6661	1705	1705	2000	2000	3	6	1000	1100	1300	1000	1200	1400
	N650	6500	2816	7455	7126	1871	1871	2200	2200	3	6	900	900	1150	1000	1000	1200

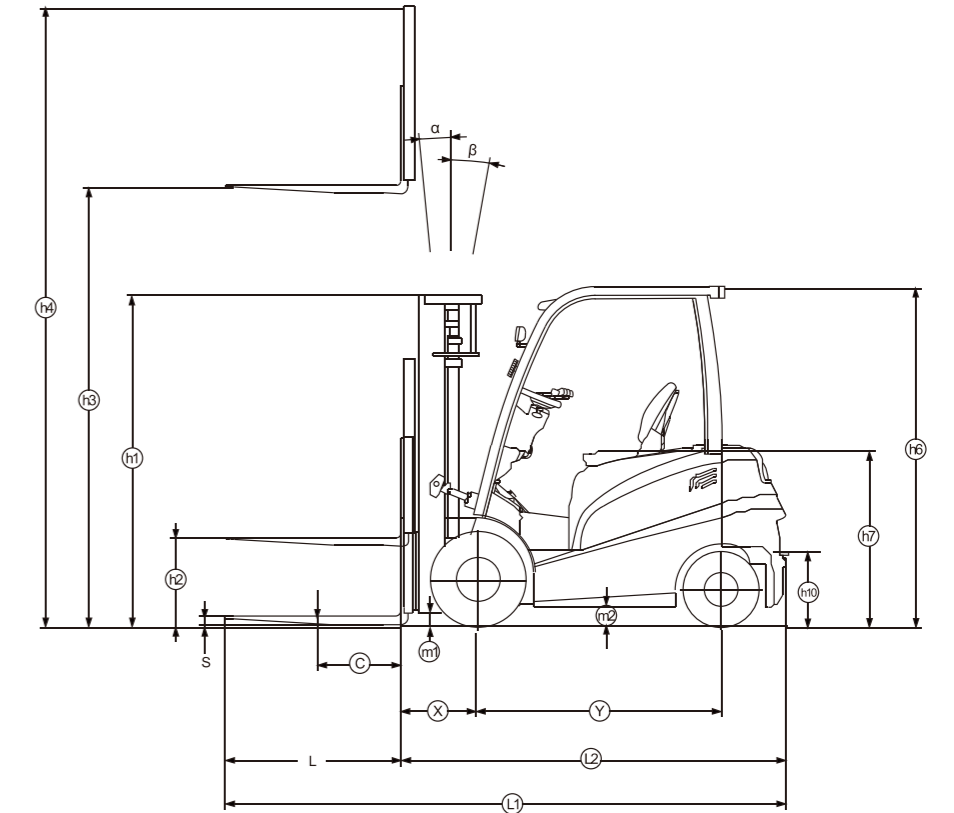

A series 2.0t/2.5t/2.5tLW mast specification

Type	Model	Lifting height	Lowered height	Extended height		Free lifting height		Tilting range		Capacity (Mast vertical to ground)			
				With backrest	Without backrest	With backrest	Without backrest	Forward	Backward	Load center@500mm Single Tire		Load center@500mm Front Dual Tire	
		mm	mm	mm	mm	mm	mm	(°)	(°)	2.0t	2.5t/2.5LW	2.0t	2.5t/2.5LW
2-stage wide view mast	M250	2500	1756	3556	3151	140	140	5	6	2000	2500	2000	2500
	M270	2700	1856	3756	3351	140	140	5	6	2000	2500	2000	2500
	M300	3000	2006	4056	3651	140	140	5	10	2000	2500	2000	2500
	M330	3300	2171	4386	3981	140	140	5	10	2000	2500	2000	2500
	M350	3500	2256	4556	4151	140	140	5	10	2000	2500	2000	2500
2-stage full-free lifting mast	M250	2500	1756	3556	3151	140	140	5	6	2000	2500	2000	2500
	U270	2700	1881	3746	3332	835	835	1249	1249	5	6	2000	2500
	U300	3000	1981	4046	3632	935	935	1349	1349	5	10	2000	2500
	U330	3300	2131	4346	3932	1085	1085	1499	1499	5	10	2000	2500
	U360	3600	2281	4646	4232	1235	1235	1649	1649	5	10	2000	2500
3-stage full-free lifting mast	U400	4000	2531	5046	4632	1485	1485	1899	1899	5	10	2000	2500
	N400	4000	1926	5056	4680	880	880	1256	1256	5	6	2000	2500
	N430	4300	2026	5356	4980	980	980	1356	1356	5	6	2000	2450
	N450	4500	2096	5606	5230	1050	1050	1426	1426	5	6	2000	2350
	N480	4800	2196	5856	5480	1150	1150	1526	1526	5	6	1950	2250
3-stage full-free lifting mast	N500	5000	2261	6056	5680	1215	1215	1591	1591	5	6	1850	2150
	N550	5500	2426	6556	6180	1380	1380	1756	1756	3	6	1750	2050
	N600	6000	2646	7066	6690	1600	1600	1976	1976	3	6	1550	1850
	N650	6500	2821	7566	7180	1775	1775	2151	2151	3	6	1300	1600

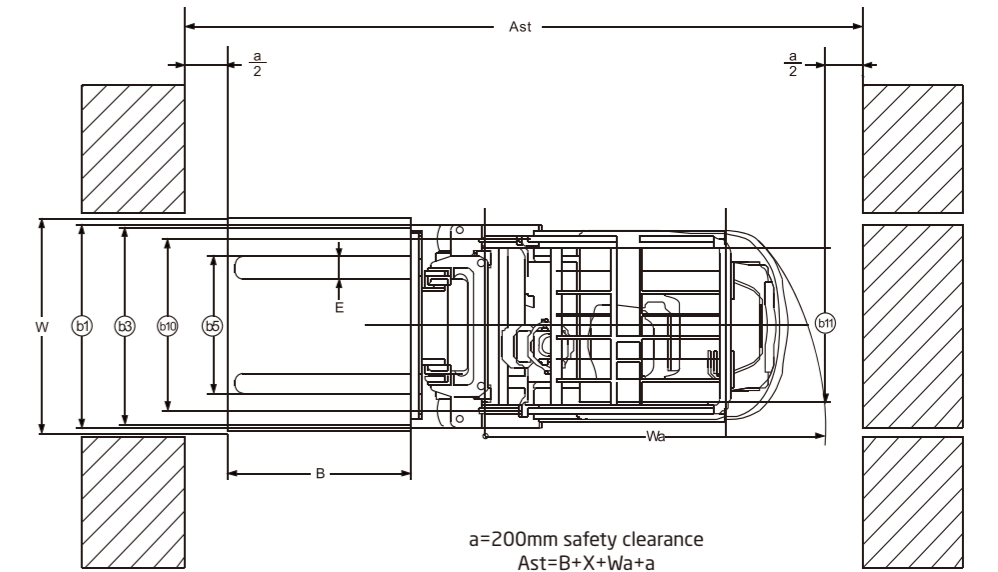

a=200mm safety clearance
Ast=B+X+Wa+a

X: Load distance
B: Length of load or forks which is longer

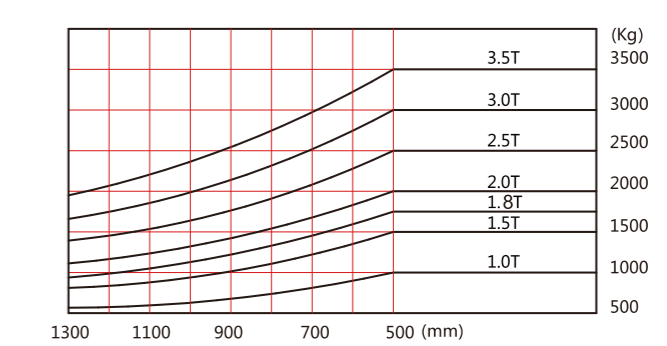

A series 3.0t/3.5t mast specification

Type	Model	Lifting height	Lowered height	Extended height				Free lifting height				Tilting range		Capacity (Mast vertical to ground)			
				With backrest		Without backrest		With backrest		Without backrest		Forward	Backward	Load center@500mm Single Tire		Load center@500mm Front Dual Tire	
		mm	mm	3.0t	3.5t	3.0t	3.5t	3.0t	3.5t	3.0t	3.5t	(°)	(°)	3.0t	3.5t	3.0t	3.5t
2-stage wide view mast	M250	2500	1786	3652	3652	3213	3288	145	150	145	150	5	6	3000	3500	3000	3500
	M270	2700	1886	3852	3852	3413	3488	145	150	145	150	5	6	3000	3500	3000	3500
	M300	3000	2036	4152	4152	3713	3788	145	150	145	150	5	10	3000	3500	3000	3500
	M330	3300	2186	4452	4452	4013	4088	145	150	145	150	5	10	3000	3500	3000	3500
	M350	3500	2286	4652	4652	4213	4288	145	150	145	150	5	10	3000	3500	3000	3500
2-stage full-free lifting mast	M250	2500	1786	3652	3652	3213	3288	145	150	145	150	5	6	3000	3500	3000	3500
	U270	2700	1926	3952	3952	3513	3588	145	150	145	150	5	6	3000	3500	3000	3500
	U300	3000	2076	4252	4252	3813	3888	145	150	145	150	5	10	3000	3500	3000	3500
	U330	3300	2226	4552	4552	4113	4188	145	150	145	150	5	10	3000	3500	3000	3500
	U360	3600	2376	4852	4852	4413	4488	145	150	145	150	5	10	3000	3500	3000	3500
3-stage full-free lifting mast	U400	4000	2626	5152	5152	4713	4788	145	150	145	150	5	10	3000	3500	3000	3500
	N400	4000	1951	5152	5152	4781	4856	809	909	1180	1205	5	6	3000	3400	3000	3500
	N430	4300	2051	5452	5452	5081	5156	909	1009	1280	1305	5	6	3000	3300	3000	3400
	N450	4500	2121	5706	5706	5335	5410	979	1079	1350	1375	5	6	3000	3200	3000	3300